

**Technical Manual BI-0316**  
**Mass Storage Module**

Product Code: BI-0316-HH-QM304550PXLW

**Version 1.2**

**January 1999**

**Documentation History**

<b>Date</b>	<b>Version</b>	<b>PCB Revision</b>	<b>Update Level</b>	<b>Change/Description</b>
94/03/09	1.0	1.0	-	First Release
94/09/09	1.1	1.0	-	Editorial Changes
99/01/27	1.2	1.1	-	PCB Changes

## **Copyright**

Copyright © 1999 by Brand Innovators of Digital Products bv. All rights reserved. No part of this publication may be reproduced, transmitted, transcribed, stored in a retrieval system, or translated into any language or computer language, in any form or by any means, electronic, mechanical, magnetic, optical, chemical, manual or otherwise, without the prior written permission of Brand Innovators of Digital Products bv, Post Office Box 1377, 5602 BJ Eindhoven - The Netherlands.

## **Disclaimer**

The information in this document has been carefully checked and is believed to be entirely reliable. However, no responsibility is assumed for inaccuracies. Brand Innovators of Digital Products bv makes no representations or warranties with respect to the contents hereof and specifically disclaims any implied warranties of merchant ability or fitness for any particular purpose. Furthermore, Brand Innovators of Digital Products bv reserves the right to make changes to any product herein to improve reliability, function or design, without obligation of Brand Innovators of Digital Products bv to notify any person of such revision or changes. Brand Innovators of Digital Products bv does not assume any liability arising out of applications or use of any product or circuit described herein; neither does it convey any license under its patent rights nor the rights of others.

## **Copyright**

Copyright (c) 1999 by COMPCONTROL INC.. All rights reserved. No part of this publication may be reproduced, transmitted, transcribed, stored in a retrieval system, or translated into any language or computer language, in any form or by any means, electronic, mechanical, magnetic, optical, chemical, manual or otherwise, without the prior written permission of COMPCONTROL INC., 15466 Los Gatos Blvd. Suite 109-365 LOS GATOS, CALIFORNIA 95032.

## **Disclaimer**

The information in this document has been carefully checked and is believed to be entirely reliable. However, no responsibility is assumed for inaccuracies. COMPCONTROL INC. makes no representations or warranties with respect to the contents hereof and specifically disclaims any implied warranties of merchant ability or fitness for any particular purpose. Furthermore, COMPCONTROL INC. reserves the right to make changes to any product herein to improve reliability, function or design, without obligation of COMPCONTROL INC. to notify any person of such revision or changes. COMPCONTROL INC. does not assume any liability arising out of applications or use of any product or circuit described herein; neither does it convey any license under its patent rights nor the rights of others.

# Table of Contents

<b>Chapter 1</b>	<b>General Information . . . . .</b>	<b>1-1</b>
1.1	Introduction. . . . .	1-1
1.2	Features . . . . .	1-1
1.2.1	SCSI Connectivity . . . . .	1-1
1.2.2	SCSI Daisy-Chaining. . . . .	1-2
1.2.3	One Slot Solution . . . . .	1-2
1.2.4	VMEbus Signals . . . . .	1-2
1.3	General Description . . . . .	1-3
1.4	Manual Updates . . . . .	1-3
1.5	Related Documents . . . . .	1-3
<b>Chapter 2</b>	<b>Functional Description. . . . .</b>	<b>2-1</b>
2.1	Introduction. . . . .	2-1
2.2	Position Numbering . . . . .	2-1
2.3	SCSI Bus Technology. . . . .	2-2
2.3.1	Overview . . . . .	2-2
2.3.2	Data Transfer Options . . . . .	2-2
2.3.3	Electrical Options . . . . .	2-2
2.4	SCSI-2 and SCSI-3 Cabling Differences . . . . .	2-3
2.4.1	SCSI-2 Cabling . . . . .	2-3
2.4.2	SCSI-3 Cabling . . . . .	2-3
2.5	SCSI Bus Connection Options . . . . .	2-3
2.5.1	SCSI-3 Option . . . . .	2-3
2.5.2	SCSI-3 Mixed With SCSI-2 Option . . . . .	2-4
2.6	SCSI Bus Backplane Connection Options . . . . .	2-5
2.6.1	Option I. Transition Module . . . . .	2-5
2.6.2	Option II. Flatcable Connection . . . . .	2-6
2.6.3	Option III. Backplane Connection . . . . .	2-7
2.7	Identification . . . . .	2-8
<b>Chapter 3</b>	<b>Installation Procedures . . . . .</b>	<b>3-1</b>
3.1	Introduction. . . . .	3-1
3.2	SCSI Bus ID Selection . . . . .	3-1
3.3	SCSI Bus Termination . . . . .	3-2
3.3.1	Internal Termination. . . . .	3-2
3.3.2	External Termination . . . . .	3-2
3.3.3	Mixing Buses Having Different Widths . . . . .	3-3



---

3.4	Spindle Sync Option . . . . .	3-3
3.5	Power Supply Considerations. . . . .	3-4
3.5.1	+5Vdc Pins. . . . .	3-4
3.5.2	+12Vdc Pins. . . . .	3-4
3.6	Installation Steps. . . . .	3-5
Appendix A	Block Diagram . . . . .	A-1
Appendix B	Schematic Diagrams. . . . .	B-1
Appendix C	Component Layout . . . . .	C-1
Appendix D	List of Components. . . . .	D-1
Appendix E	Connector Assignments . . . . .	E-1
Appendix F	Drive 1 Manual . . . . .	F-1
Appendix G	Drive 2 Manual . . . . .	G-1



# List of Figures

Figure 1-1	View of Module . . . . .	1-1
Figure 1-2	SCSI Daisy-Chaining . . . . .	1-2
Figure 2-1	Position Numbering . . . . .	2-1
Figure 2-2	SCSI-3 Daisy-Chain Option . . . . .	2-4
Figure 2-3	SCSI-3 to SCSI-2 Daisy-Chain Option . . . . .	2-4
Figure 2-4	Option I - Transition Module . . . . .	2-6
Figure 2-5	Option II - Flatcable Connection . . . . .	2-7
Figure 2-6	Option III - Backplane Connection . . . . .	2-7
Figure 3-1	ID Selection PCB Version 1.0 . . . . .	3-1
Figure 3-2	ID Selection PCB Version 1.1 . . . . .	3-1
Figure 3-3	Internal Termination PCB Version 1.0 . . . . .	3-2
Figure 3-4	Internal Termination PCB Version 1.1 . . . . .	3-2
Figure 3-5	Spindle Sync Option PCB Version 1.0 . . . . .	3-3
Figure 3-6	Spindle Sync Option PCB Version 1.1 . . . . .	3-4
Figure A-1	BI-0316 Block Diagram . . . . .	A-1
Figure C-1	Component Layout PCB Version 1.0 . . . . .	C-1
Figure C-2	Component Layout PCB Version 1.1 . . . . .	C-2



# List of Tables

Table 1-1	Manual Updates . . . . .	1-3
Table 1-2	Related Documents . . . . .	1-3
Table 2-1	Termination Products for 68-pin High Density Connector . . . . .	2-4
Table 2-2	Termination Products for 50-pin Low Density Connector . . . . .	2-5
Table 3-1	Termination Products for SCSI-3 to SCSI-2 FeedThru. . . . .	3-3
Table D-1	List of Components . . . . .	D-1
Table E-1	VMEbus P1 Assignments. . . . .	E-1
Table E-2	VMEbus P2 Assignments (Single-Ended) . . . . .	E-2
Table E-3	VMEbus P2 Assignments (Differential) . . . . .	E-3
Table E-4	P3, P5-P6 SCSI-3 Connectors (Single-Ended) . . . . .	E-4
Table E-5	P3, P5-P6 SCSI-3 Connectors (Differential) . . . . .	E-5
Table E-6	P7-P10 SCSI-2 Connectors (Single-Ended) . . . . .	E-6
Table E-7	P7-P10 SCSI-2 Connectors (Differential). . . . .	E-7
Table E-8	P11-P12 Power Connectors. . . . .	E-8
Table E-9	P14 Drive Options Jumper Block . . . . .	E-8
Table E-10	P15-P16 Drive Options Connector . . . . .	E-8
Table F-1	Jumper Setting Drive 1. . . . .	F-1
Table G-1	Jumper Setting Drive 2. . . . .	G-1



---

## 1.1 Introduction

This manual provides general information, preparation for use, installation instructions and theory of operation for the BI-0316.

The BI-0316 provides 3.5" or smaller form factor devices in a convenient double Eurocard form factor. The BI-0316 offers a full line of mass-storage subsystems that covers a variety of configurations with corresponding performance, capacities, and prices.

For detailed information about the mounted drives on the BI-0316 see "Drive 1 Manual" on page F-1 and "Drive 2 Manual" on page G-1. For detailed information about the SCSI standards or the software needed to operate SCSI based products see Table 1-2, "Related Documents" on page 1-3.

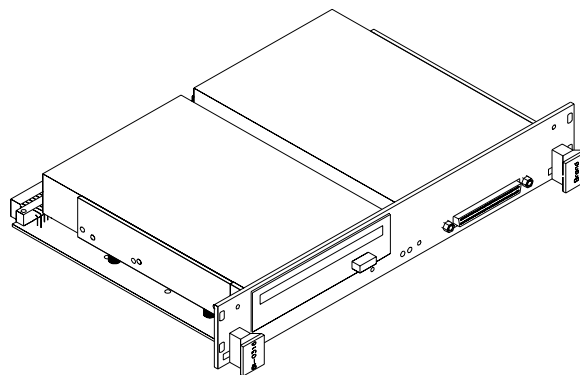

**Figure 1-1 View of Module**

---

## 1.2 Features

The BI-0316 integrates floptical and floppy disk drives, hard disk drives, DAT tape units, mini-cartridge drives and rewritable optical disk drives into compact mass-storage subsystems.

### 1.2.1 SCSI Connectivity

The BI-0316 provides connectivity through SCSI-1, SCSI-2 and SCSI-3 interfaces:

- 8-bit and 16-bit devices can be mixed on one module
- Single-Ended and Differential mode supported
- asynchronous and synchronous mode supported
- FAST and WIDE mode supported giving up to 20 Mbyte/sec transfer rate





The drives on the BI-0316 are accessible via the 68 pin high density connector on the front or via the SCSI bus signals which are available at the User Defined VMEbus P2 connector pins. A host VMEbus module normally connects to the BI-0316 using a P-Cable at the front or by using a 68 (SCSI-3) or 50 (SCSI-2) wire flatcable at the rear of the module.

The BI-0316 is not memory mapped in the VMEbus address space, this in contrary to other products which use the VMEbus for data transfers. The BI-0316 module does not occupy any address in the VMEbus address space and does not rely on any signal (except power) to be available from the VMEbus. This means that transferring data from or to the BI-0316 does not use any bandwidth of the VMEbus backplane.

### 1.2.2 SCSI Daisy-Chaining

In order to support daisy-chain connections, the BI-0316 provides two shielded SCSI-3 device connectors. One on the front and another at the VMEbus P2 connector.

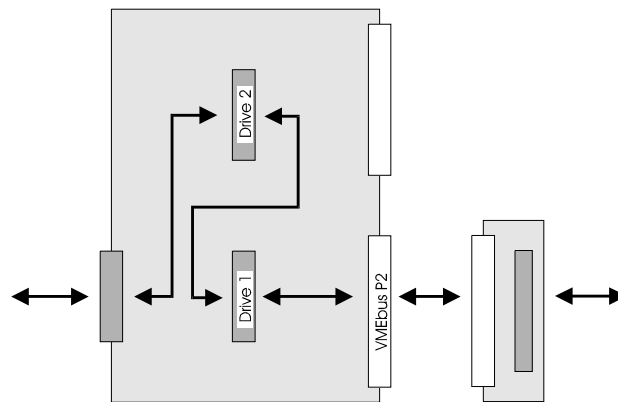

Figure 1-2 SCSI Daisy-Chaining

Inside the BI-0316 the SCSI signals are looped from the front to the rear connector. The loop passes the connection points of the drives on the BI-0316 in such a manner that stub lengths are minimized.

The length of the SCSI signals on the BI-0316 is 0.90 meter.

### 1.2.3 One Slot Solution

The BI-0316 subsystems have the standard VMEbus double Eurocard form factor and take either one, two or three slots in a VMEbus rack depending on the height of the fitted drives.

### 1.2.4 VMEbus Signals

The VMEbus Interrupt Acknowledge and Bus Grant daisy-chain signals are routed on the BI-0316 to facilitate Automatic-Daisy-Chain (ADC) backplanes.

The VMEbus ACFAIL\* signal is used to warn the SCSI devices for a coming loss of power. The drives can use this signal to prevent write interruptions within a data block. Note that this feature is only active when the drives that are installed include this feature.

## 1.3 General Description

The 3.5" form factor devices supplied with a SCSI interface make it possible to design VMEbus modules which contain two of these devices in any combination.

The BI-0316 offers up to two drives, both with a full implementation of the SCSI bus on a single VMEbus compatible module. Both drives have their own address on the SCSI bus and therefore operate independently of each other. Drives with different widths and/or cabling options (SCSI-2 or SCSI-3) can be mixed on the BI-0316. Both the Single-Ended and Differential option is supported.

The BI-0316 consists of a double Eurocard form factor base board with SCSI-2 and SCSI-3 type of connectors. The base board contains no electronics except the light emitting diodes (LEDs) and ACFAIL\* buffers. On this board, 3.5" form factor devices are mounted which connect to the base board using standard SCSI-2 or SCSI-3 cables. The LEDs are connected to the activity and fault signals of the mounted devices. Rotary switches and jumper blocks are available for SCSI ID selection and enabling of the termination of the SCSI bus signals.

## 1.4 Manual Updates

Table 1-1 Manual Updates

Revision	Changes	Additions	Deletions
1.0			
1.1	Editorial Changes		
1.2	Position of jumper block and switches		

## 1.5 Related Documents

Table 1-2 Related Documents

Document Title			
Small Computer System Interface	SCSI-1	X3T9 - I/O Interface	X3.131-1986
Small Computer System Interface	SCSI-2	X3T9 - I/O Interface	X3.131-1993
SCSI-3 Parallel Interface	SPI	X3T9.2/855D	Draft
SCSI-3 Interlocked Protocol	SIP	X3T9.2/856D	Draft
SCSI-3 Architecture Model	SAM	X3T9.2/994D	Draft
SCSI-3 Primary Commands	SPC	X3T9.2/995D	Draft
SCSI-3 Block Commands	SBC	X3T9.2/996D	Draft
SCSI-3 Stream Commands	SSC	X3T9.2/997D	Draft
SCSI-3 Medium Changer Commands	SMC	X3T9.2/999D	Draft





## 2.1 Introduction

This chapter provides an overview of the BI-0316 module. The block diagram of the module is shown in “BI-0316 Block Diagram” on page A-1 and the schematics are shown in “Schematic Diagrams” on page B-1.

## 2.2 Position Numbering

The BI-0316 holds up to two drives that are further referred to as drive 1 in position 1 and drive 2 in position 2.

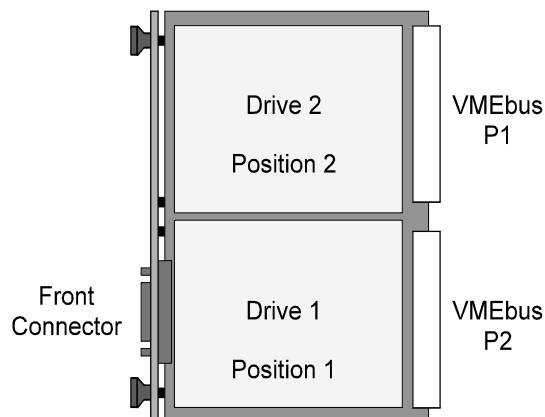

**Figure 2-1 Position Numbering**

This numbering scheme is used for identification of the devices and their position on the BI-0316. Detailed information about the drives that are mounted on the BI-0316 is available in appendices “Drive 1 Manual” on page F-1 and “Drive 2 Manual” on page G-1.

The numbering scheme has no relation to the SCSI IDs of the drives on the SCSI bus. The numbering scheme indicates the physical order of the drives on the SCSI bus as observed from the VMEbus P2 connector to the front connector. When using the internal termination option of the drives, enable this option on the last drive of the SCSI cable.

---

## 2.3 SCSI Bus Technology

The interface used by the BI-0316 is the “**Small Computer System Interface**” (SCSI) bus standard. Different versions of this standard exist. A brief introduction to the standard is given in the following sections.

### 2.3.1 Overview

SCSI is a local I/O bus that can operate over a wide range of data rates. The primary objective of this interface is to provide host computers with device independence within a class of devices. Thus, different disk drives, tape drives, printers, optical media drives, and other devices can be added to a host computer without requiring modifications to generic system hardware or software.

### 2.3.2 Data Transfer Options

The SCSI protocol is designed to provide an efficient peer-to-peer I/O bus with up to 8, 16, or 32 devices depending on the data path widths implemented, including one or more hosts. Data may be transferred asynchronously at rates that depend primarily on device implementation and cable length. Synchronous data transfers are supported at rates up to 10 megatransfers per second. Three data path widths are allowed, 8-bit, 16-bit, and 32-bit. The corresponding maximum transfer rates are 10, 20, and 40 megabytes per second.

Data transfers are divided into three speed classes: asynchronous, slow, and fast. A *transfer period* specifies the minimum time allowed between the leading edges of successive REQ pulses and of successive ACK pulses while using synchronous data transfers.

- Fast data transfers require a transfer period greater than 100 ns. and less than 200 ns. with a REQ/ACK offset greater than zero. If a fast data transfer is agreed upon, fast timing shall be observed even though the actual data transfer period is greater than or equal to 200 ns.
- Slow data transfers require a transfer period greater than or equal to 200 ns. with a REQ/ACK offset greater than zero.
- Asynchronous information transfers require a REQ/ACK offset of zero. The transfer period does not apply to these information transfers.

The BI-0316 supports all three classes.

### 2.3.3 Electrical Options

There are two electrical alternatives for the SCSI bus:

- Single-Ended and
- Differential.

Single-Ended and Differential devices are electrically incompatible and can not be mixed on the same physical bus.

When the BI-0316 contains Single-Ended drives it can be used in a Single-Ended SCSI bus. When the BI-0316 contains Differential drives it can be used in a Differential SCSI bus.

---

## 2.4 SCSI-2 and SCSI-3 Cabling Differences

The BI-0316 supports both the traditional SCSI (or SCSI-1) and SCSI-2 version as well as the new SCSI-3 version. For reasons of clarity, when referring to the 8-bit SCSI, SCSI-1 or SCSI-2 versions, the term SCSI-2 will be used.

### 2.4.1 SCSI-2 Cabling

SCSI-2 devices are daisy-chained using a common 50-conductor A-cable and, optionally, a 68-conductor B-cable. Both ends of each cable are terminated. The primary SCSI-2 bus carries an 8-bit data bus and control signals. A primary SCSI-2 bus A-cable provides therefore an 8-bit data path. In systems that employ the wide SCSI option, wide SCSI devices additionally connect to the B-cable. This secondary SCSI-2 bus carries an additional 24-bit data bus that, used in conjunction with a primary SCSI-2 bus, provides a 32-bit data path.

The BI-0316 supports the A-cable option of the SCSI-2 standard.

### 2.4.2 SCSI-3 Cabling

SCSI-3 devices are daisy-chained using a common 68-conductor P-cable and, optionally, a 68-conductor Q-cable. Both ends of each cable are terminated. The primary SCSI-3 bus carries a 16-bit data bus and control signals. A primary SCSI-3 bus P-cable provides therefore a 16-bit data path. A secondary SCSI-3 bus Q-cable carries an additional 16-bit bus that, used in conjunction with a primary SCSI-3 bus, provides a 32-bit data path.

The BI-0316 supports the P-cable option of the SCSI-3 standard.

---

## 2.5 SCSI Bus Connection Options

The BI-0316 can be connected to a SCSI bus initiator through the front or via the backplane connector. When the host is connected to the front connector, the backplane connector can be used to terminate or daisy-chain the SCSI bus signals. When the host is connected to the backplane connector, the front connector can be used for termination or daisy-chaining of the SCSI bus signals.

At the front, a 68-pin high density connector (P3) with 2-56 jack screws for cable retention is used. This connector complies to the SCSI-3 standard and connects directly to a Single-Ended or Differential bus SCSI-3 P-cable.

The P3 connector contact assignments for Single-Ended use can be found in Table E-4, "P3, P5-P6 SCSI-3 Connectors (Single-Ended)" on page E-4. When the BI-0316 is used in a Differential bus the contact assignments are given in Table E-5, "P3, P5-P6 SCSI-3 Connectors (Differential)" on page E-5.

### 2.5.1 SCSI-3 Option

This option uses the BI-0319 to connect to the SCSI bus signals on the VMEbus P2.



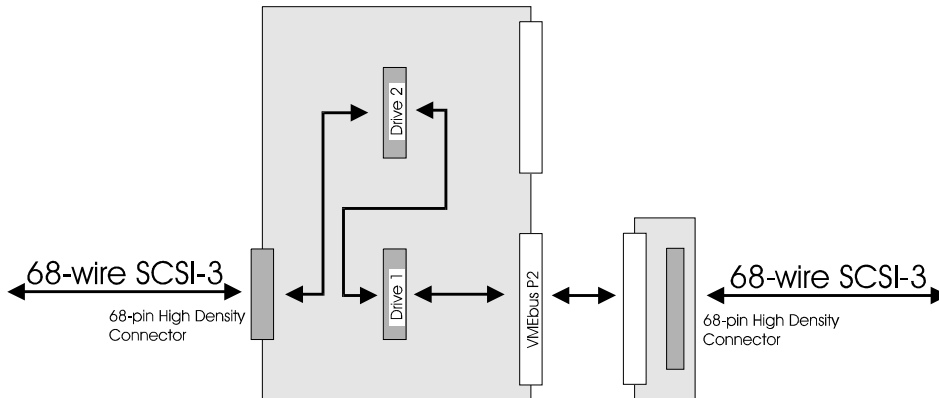

Figure 2-2 SCSI-3 Daisy-Chain Option

This setup connects the BI-0316 to a 16-bit (WIDE) Single-Ended or Differential SCSI bus. Note that if either the cable at the front or at the rear connector is not inserted, termination must be applied to this connector. The following table contains a list of products to achieve this termination.

Table 2-1 Termination Products for 68-pin High Density Connector

Product	Description	Manufacturer
0-0869516-1	Amplimite .050 Series SCSI-3 Terminator Low Profile with Jack Screws, Single-Ended 68 positions	AMP
0-0869515-1	Amplimite .050 Series SCSI-3 Terminator Low Profile with Jack Screws, Differential 68 positions	AMP

When the cable at the front has to connect to an 8-bit device, special care has to be given to the Upper Byte termination. See "Mixing Buses Having Different Widths" on page 3-3.

### 2.5.2 SCSI-3 Mixed With SCSI-2 Option

This option uses the BI-0318 to connect to the SCSI bus signals on the VMEbus P2.

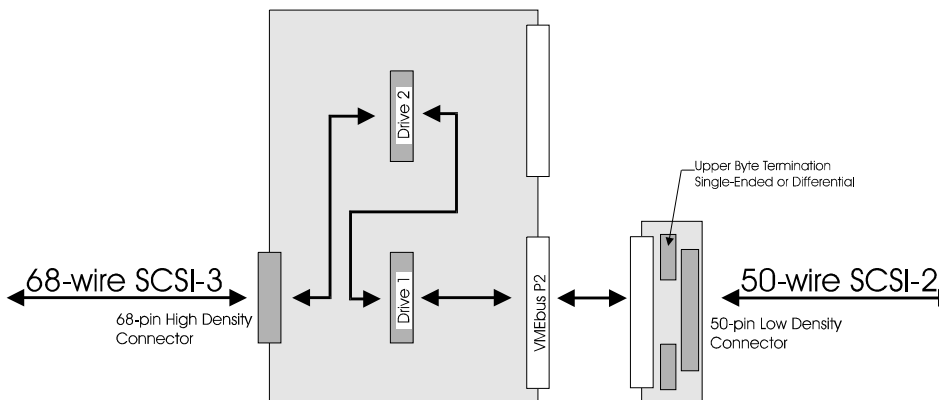

Figure 2-3 SCSI-3 to SCSI-2 Daisy-Chain Option

This setup connects the BI-0316 to a 16-bit (WIDE) bus at the front and a 8-bit bus at the rear of the module. Note that the upper byte signals must be terminated on the 16-bit to 8-bit adapter. This is achieved by the on-board terminators of the BI-0318 module. These terminators are capable of terminating Single-Ended as well as Differential SCSI buses.

**Table 2-2 Termination Products for 50-pin Low Density Connector**

Product	Description	Manufacturer
0-0869576-1	Ampmodu Unshielded Receptacle SCSI-2 Terminator, Low Density, Single-Ended, 50 positions	AMP
0-0869041-1	Ampmodu Unshielded Receptacle SCSI-2 Terminator, Low Density, Differential, 50 positions	AMP

See also "Mixing Buses Having Different Widths" on page 3-3.

## 2.6 SCSI Bus Backplane Connection Options

At the backplane different connection options are available:

- Option I: using a transition module on the VMEbus P2 connector
- Option II: using a flat cable connection on the VMEbus P2 connector
- Option III: using a special backplane layout to the VMEbus P2 connector

All three options can be used for 8-bit and 16-bit solutions in Single-Ended and Differential configurations.

### 2.6.1 Option I. Transition Module

This is the most common and versatile option. It gives the capability to connect 8-bit and 16-bit cables to the BI-0316. It gives also the capability to connect external terminators.





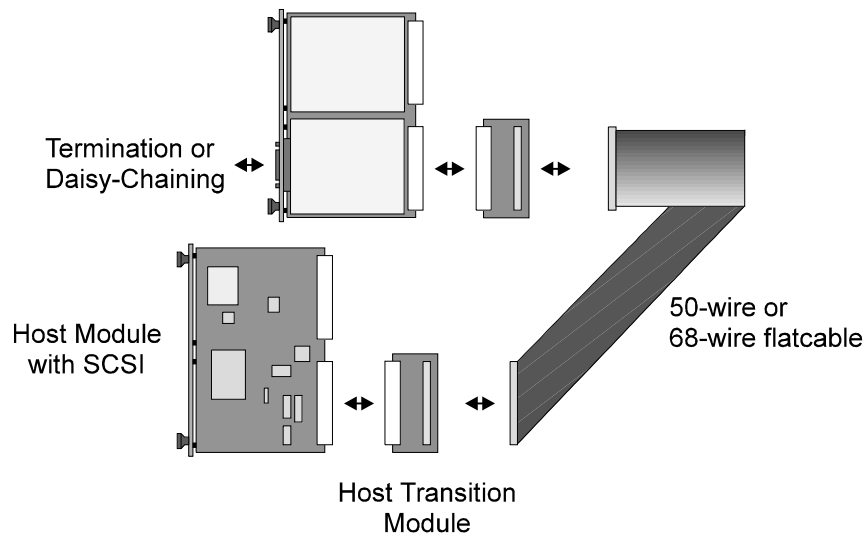

**Figure 2-4 Option I - Transition Module**

The BI-0318 and BI-0319 are modules that fit on the VMEbus P2 connector of the BI-0316. They route the SCSI signals of the VMEbus P2 connector to standard SCSI-2 and SCSI-3 connectors. The BI-0318 and BI-0319 serve several functions:

- enable daisy-chaining of the SCSI-2 and SCSI-3 cables
- allowing external termination
- support mixing of 8- and 16-bit cables

The BI-0318 and BI-0319 Transition Modules can be used in VMEbus systems that are fitted with or without a J2 backplane. In either case the BI-0318 and BI-0319 provide universal solutions with their SCSI-2 and SCSI-3 type of connectors. See the Technical Manual of the BI-0318 and BI-0319 for the installation details.

### 2.6.2 Option II. Flatcable Connection

This option can be used when the SCSI host module has a VMEbus P2 pin layout compatible with the BI-0316.

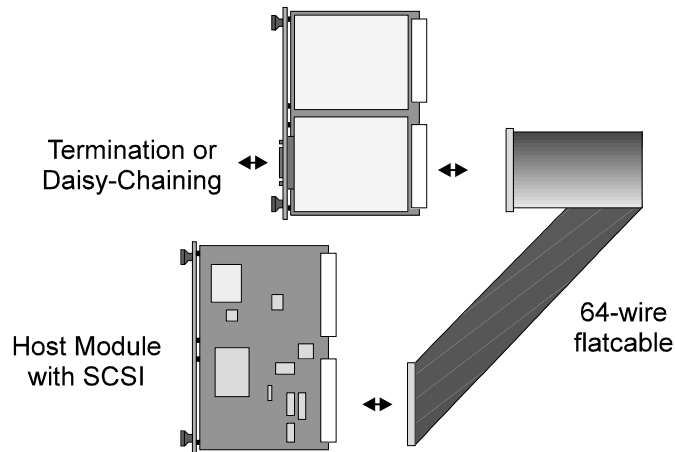
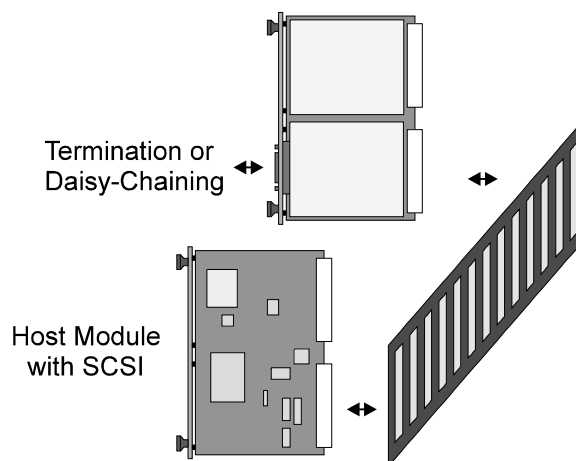

**Figure 2-5 Option II - Flatcable Connection**

A 64-wire flatcable connects corresponding pins on the VMEbus P2 connectors of the host module and the BI-0316. The VMEbus P2 pin assignments of the BI-0316 are given in Table E-3, “VMEbus P2 Assignments (Differential)” on page E-3 and Table E-3, “VMEbus P2 Assignments (Differential)” on page E-3.

**2.6.3 Option III. Backplane Connection**

This option can be used in dedicated systems where it is known which VMEbus modules are inserted in the VMEbus backplane.



**Figure 2-6 Option III - Backplane Connection**



A backplane is constructed which connects corresponding User Defined pins on the VMEbus P2 connectors of the host module and the BI-0316. The VMEbus P2 pin assignments of the BI-0316 are given in Table E-3, "VMEbus P2 Assignments (Differential)" on page E-3 and Table E-3, "VMEbus P2 Assignments (Differential)" on page E-3.

---

## 2.7 Identification

A label is used to identify the drives on the BI-0316. The text on this label includes:

- board revision of the BI-0316
- board serial number
- type of drive(s) mounted
- serial number of the drive(s)
- SCSI ID number of the drive(s)
- termination options installed

### 3.1 Introduction

This chapter provides the preparation and installation instructions for the BI-0316 module.

### 3.2 SCSI Bus ID Selection

A SCSI bus supports 8, 16 or 32 devices depending on the cable width used. Each device must have a unique SCSI ID assigned. The SCSI IDs of the devices fitted can be selected using the switches available on the BI-0316.

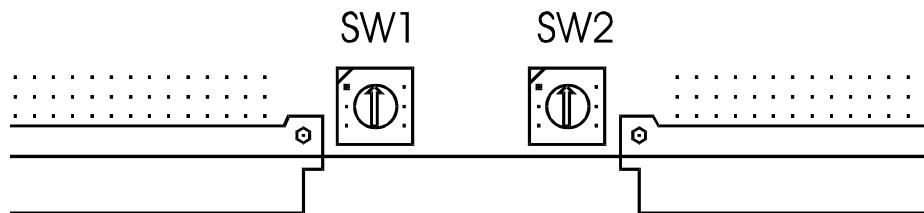

Figure 3-1 ID Selection PCB Version 1.0

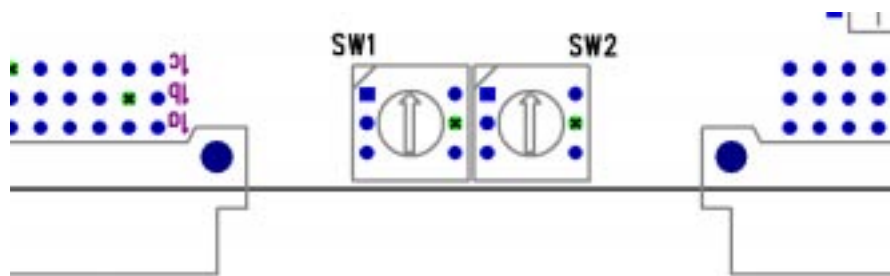

Figure 3-2 ID Selection PCB Version 1.1

The device ID selection for each drive is accomplished using a hex rotary DIP switch. The SCSI ID of drive 1 in position 1 is set with switch SW1, the SCSI ID of drive 2 is set with SW2. For 8-bit devices IDs 0 to 7 are used, for 16-bit devices IDs 0 to F are valid.

### 3.3 SCSI Bus Termination

A SCSI bus must be terminated on both ends of the cable. Termination resistors can be either installed internally on the mounted drives or with external terminators.

#### 3.3.1 Internal Termination

When the BI-0316 is at the physical end of the SCSI cable, the internal termination option of the mounted drives can be used. When this option is put to use be sure to enable the terminators on drive 1 in position 1 when a front connection is used. When the VMEbus P2 connector is used, then enable termination on drive 2 in position 2. When the BI-0316 contains drives with different widths, enable the termination option for the drive with the wider bus to ensure all signals are terminated.

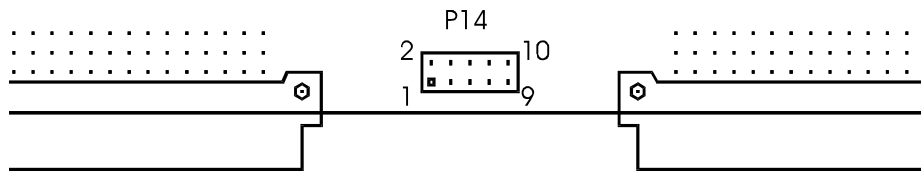

Figure 3-3 Internal Termination PCB Version 1.0

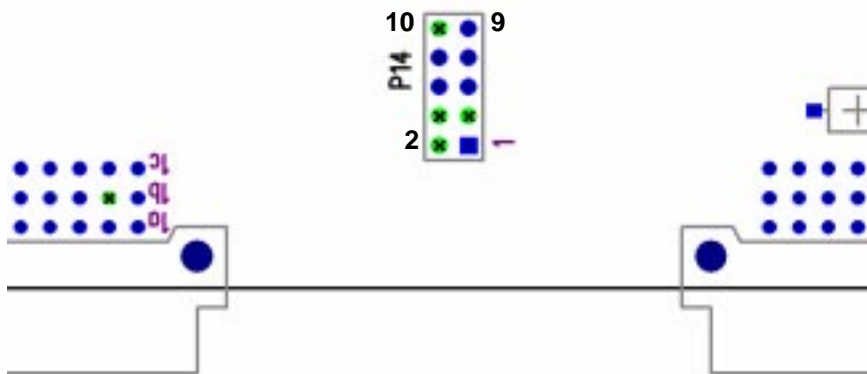

Figure 3-4 Internal Termination PCB Version 1.1

Jumper block P14 is used to enable the termination options of the drives. The termination option of drive 1 in position 1 is enabled when pins 1 and 2 of P14 are jumpered. When pins 9 and 10 of P14 are jumpered then the termination option of drive 2 in position 2 is enabled.

#### 3.3.2 External Termination

For external termination see the discussions in the sections “SCSI-3 Option” on page 2-3 and “SCSI-3 Mixed With SCSI-2 Option” on page 2-4.

### 3.3.3 Mixing Buses Having Different Widths

When buses of dissimilar width are adapted to one another, the DATA BUS signals from the wider of the two buses that end at the adapter should be terminated at the adapter.

When the adapter is the BI-0318, termination is provided by the termination resistors on this board. Be sure to enable the appropriate (Single-Ended or Differential) set of terminators. See also the section “SCSI-3 Mixed With SCSI-2 Option” on page 2-4.

When a SCSI-3 cable is connected to the front of the BI-0316 which has to be connected to a 8-bit device, the following products are available to provide proper termination.

**Table 3-1 Termination Products for SCSI-3 to SCSI-2 FeedThru**

Product	Description	Manufacturer
0-0869680-1	AMP SCSI terminator, High Density AMPLIMITE .050 Series Shielded FeedThru Terminator, 68-position female to 50-position male, Single-Ended	AMP
0-0869678-1	AMP SCSI terminator, High Density AMPLIMITE .050 Series Shielded FeedThru Terminator, 68-position female to 50-position male, Differential	AMP

## 3.4 Spindle Sync Option

When two drives of the same manufacturer and type are used then the spindle synchronization option can be activated.

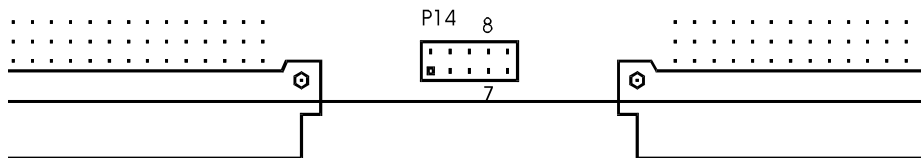

**Figure 3-5 Spindle Sync Option PCB Version 1.0**



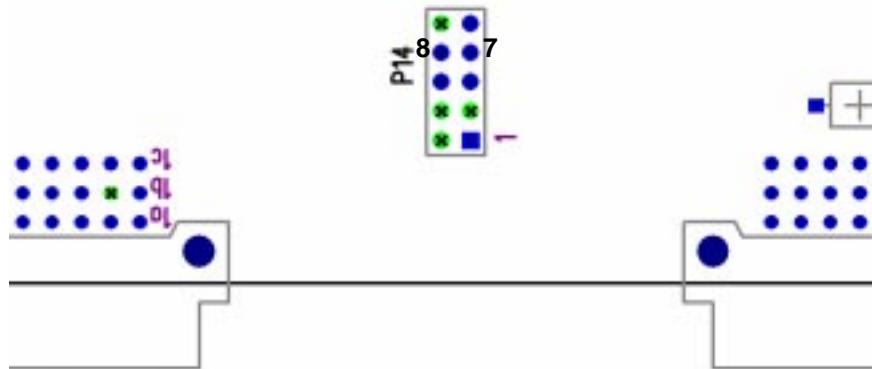

Figure 3-6 Spindle Sync Option PCB Version 1.1

When a jumper is placed on pins 7 and 8 of P14, the spindle synchronization signal of drive 1 is connected to the spindle synchronization signal of drive 2. Note that further SCSI commands to the drives are needed to make the spindle synchronization option active.

## 3.5 Power Supply Considerations

The connectors P1 and P2 to the VMEbus serve several functions:

- give strength to the board
- connect the power supply pins of the VMEbus backplane
- give access to the SCSI bus signals through the P2 connector

In addition to the Ground pins two power supply connections are used by the BI-0316: +5Vdc and +12Vdc.

### 3.5.1 +5Vdc Pins

The VMEbus P1 connector provides three pins for +5Vdc and another three +5Vdc pins are available on the VMEbus P2 connector. These pins supply enough current for any combination of drives on the BI-0316.

### 3.5.2 +12Vdc Pins

The single +12Vdc pin on the VMEbus P2 connectors allows for at least 12 Watts of power to the mounted drives. This is sufficient for almost all combinations possible with the BI-0316. For modules that draw more current from the +12Vdc than is allowed via the single VMEbus P1 connector pin, an extra +12Vdc pin is defined on the VMEbus P2 connector. This pin can be externally connected to the +12Vdc power supply used on the VMEbus using the BI-0318 or BI-0319 transition module. When Brand Innovators encounters such a need for a module, it will clearly state this in its deliveries.

### 3.6 Installation Steps

1. Choose the SCSI IDs and termination options for the drives on the BI-0316. Adjust switch settings and/or termination options when necessary.
2. Choose a position for the BI-0316 in the VMEbus rack. Placing the BI-0316 in the last (righter most) position has several advantages:
  - a) It eases the bus request and interrupt daisy-chaining in the case that the backplane does not provide Automatic-Daisy-Chaining (ADC). In the event that there are boards placed in positions right from the position the BI-0316 occupies, it is necessary to jumper the daisy-chain signals behind the BI-0316 to allow them to propagate down the chain. The BI-0316 provides daisy-chaining for the first slot it occupies (see "VMEbus Signals" on page 1-2).
  - b) The Ground layer in the Printed Circuit Board of the BI-0316 will protect the drives from electrical interference from the boards to the left of the BI-0316 in the system.
3. Place the BI-0318 or BI-0319 in opposite of the BI-0316 on the VMEbus J2 backplane or directly on the VMEbus P2 connector of the BI-0316 if no VMEbus J2 backplane is installed.
4. Connect a SCSI-2 or SCSI-3 cable to the appropriate connector on the transition module or front connector.







# Appendix A Block Diagram

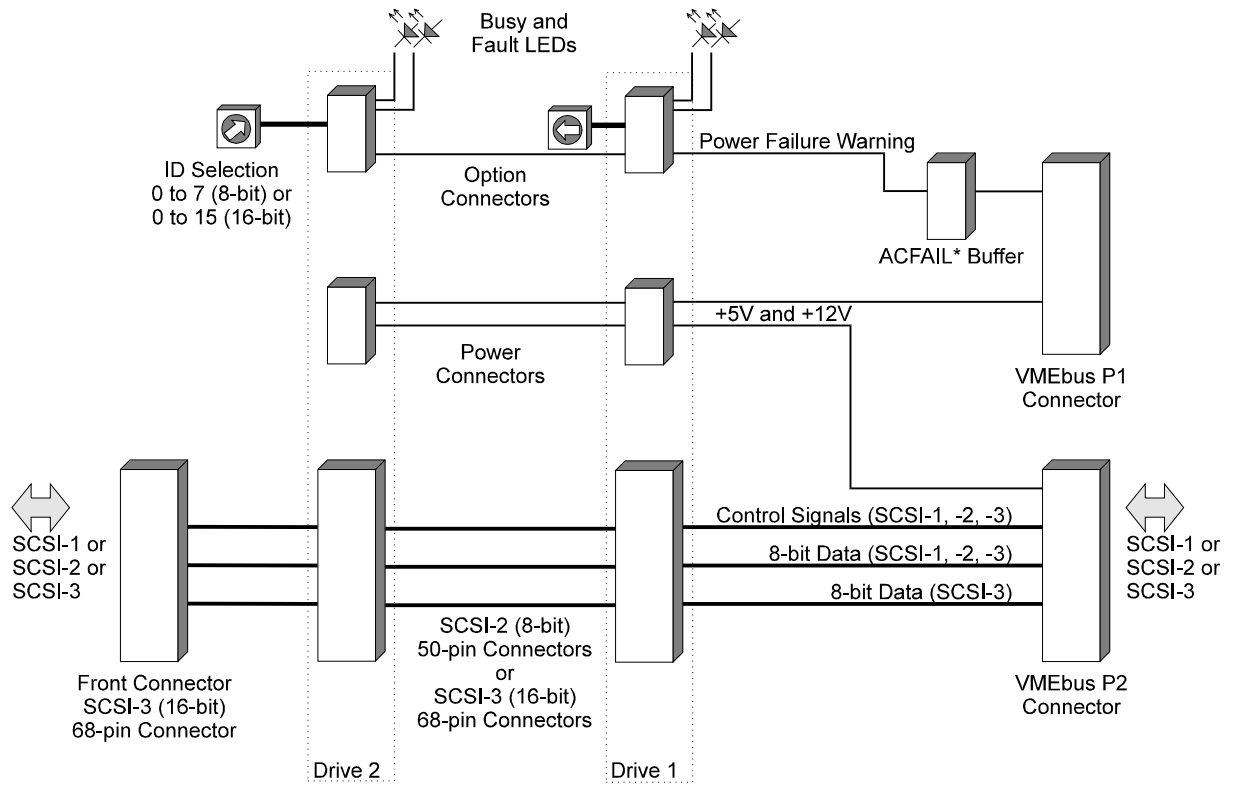

Figure A-1 BI-0316 Block Diagram





# Schematic Diagrams

Sheet 1	System Overview .....	B-2
Sheet 2	VMEbus P1 .....	B-3
Sheet 3	VMEbus P2 .....	B-4
Sheet 4	Power Connectors and LEDs .....	B-5
Sheet 5	SCSI-3 Connectors P5.....	B-6
Sheet 6	SCSI-3 Connector P6.....	B-7
Sheet 7	SCSI-3 Connector P3.....	B-8
Sheet 8	SCSI-2 Connector P7.....	B-9
Sheet 9	SCSI-2 Connector P8.....	B-10
Sheet 10	SCSI-2 Connector P9.....	B-11
Sheet 11	SCSI-2 Connector P10.....	B-12

**Important Note:**

On the schematics that follow, the *signal names* are not the standard SCSI names. These internal names are used to allow the BI-0316 to function in a Single-Ended as well as a Differential bus. Although the *signal naming* is not standard, the *electrical signals* and the *pin numbers* of the physical connectors conform to the SCSI standards.

Please use the tables provided in Appendix E "Connector Assignments" to find the proper signal naming and pin numbering of the VMEbus P2 and SCSI connectors. Two tables are given for each connector, one for Single-Ended and one for Differential use.



Sheet 1 System Overview

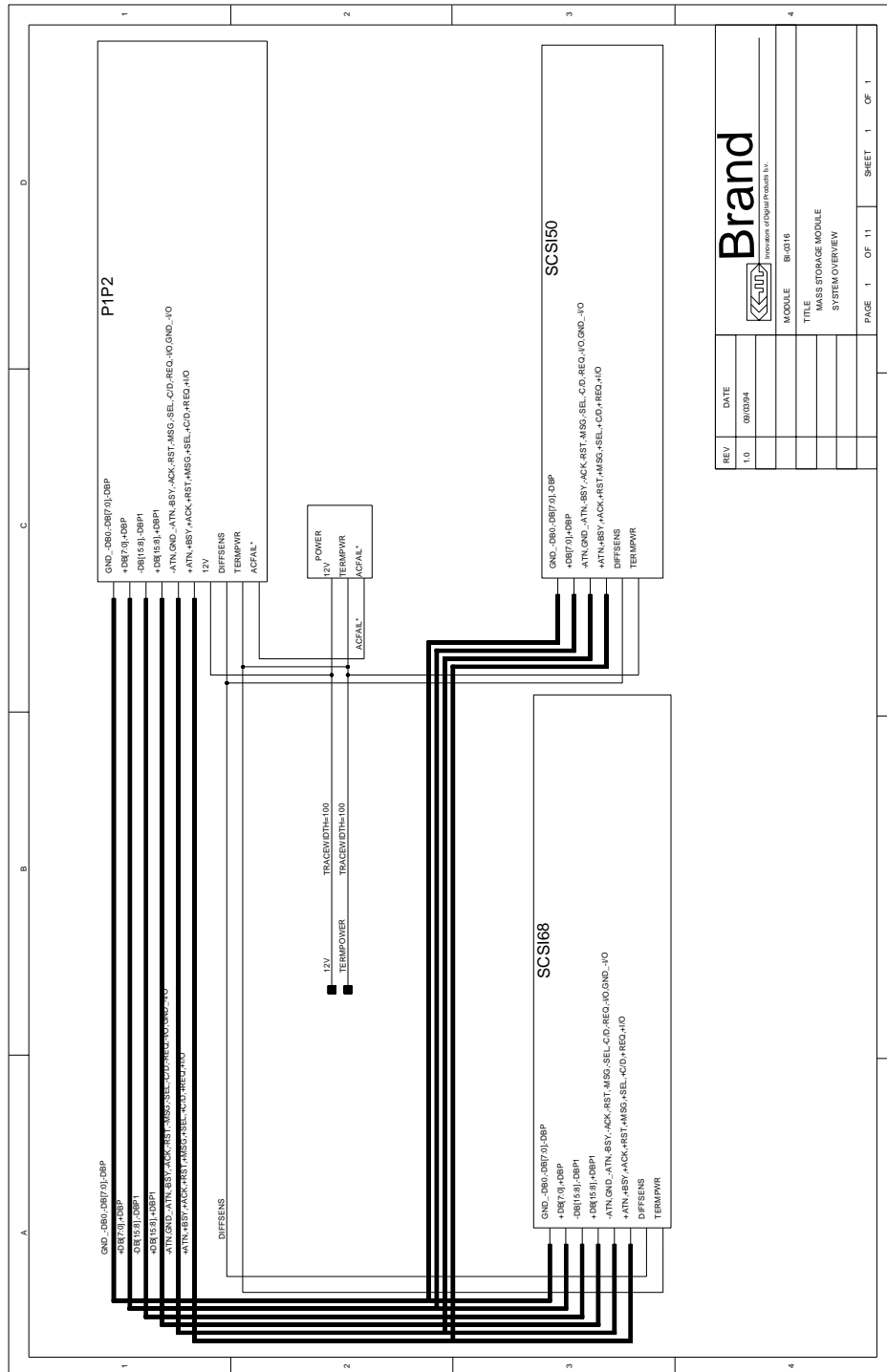

REV	DATE
1.0	08/08/04

<b>Brand</b> <small>Innovators of Digital Protection Ex.</small>	
MODULE	BI-0316
TITLE	BIOS STORAGE MODULE SYSTEM OVERVIEW
PAGE	1 OF 11
SHEET	1 OF 1



Sheet 2 VMEbus P1

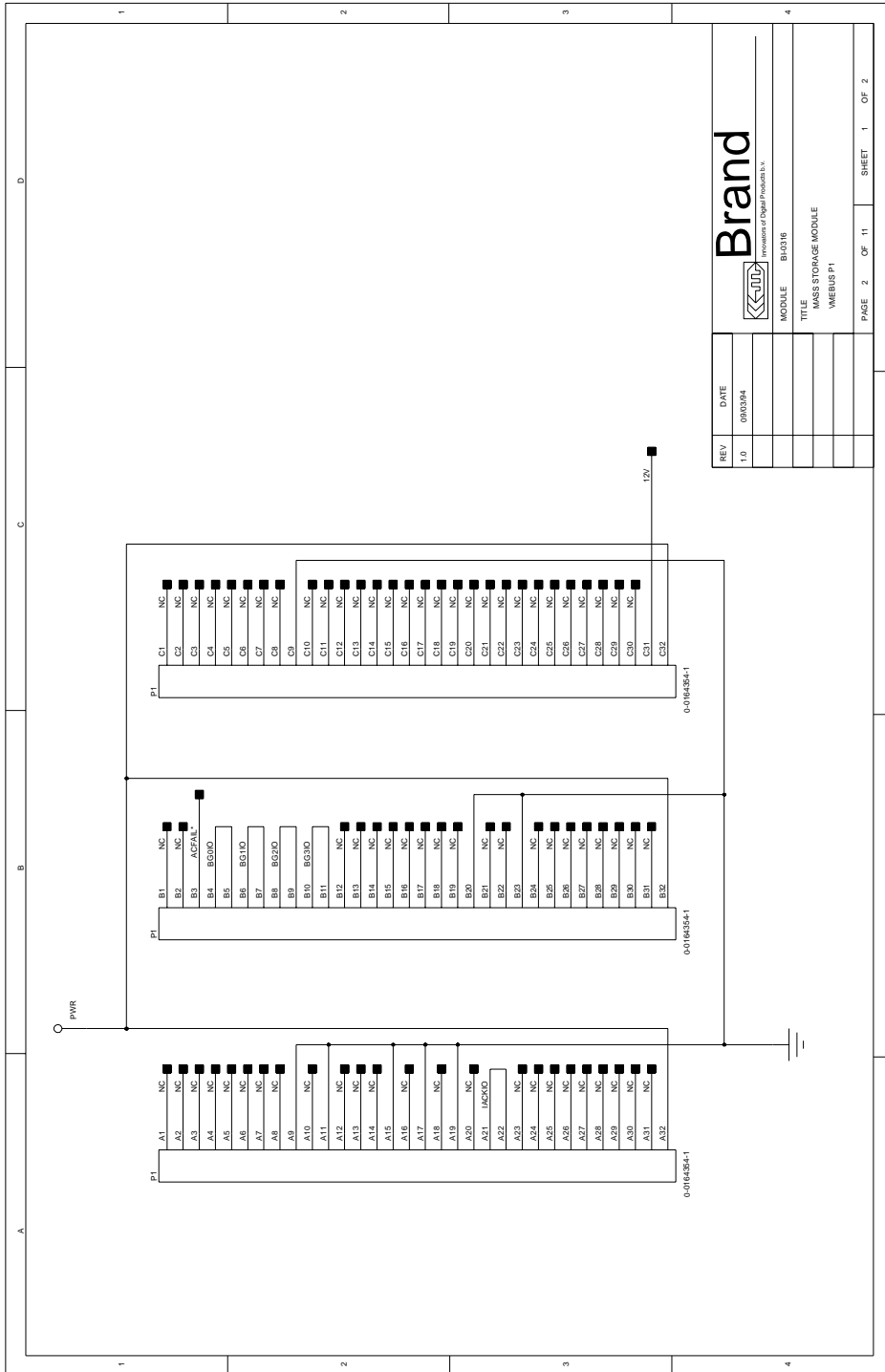

Inventors of Digital Products S.A.

MODULE BI4338

TITLE MASS STORAGE MODULE  
VMEBUS P1

REV	DATE
1.0	08/03/94

PAGE 2 OF 11 SHEET 1 OF 2



Sheet 3 VMEbus P2

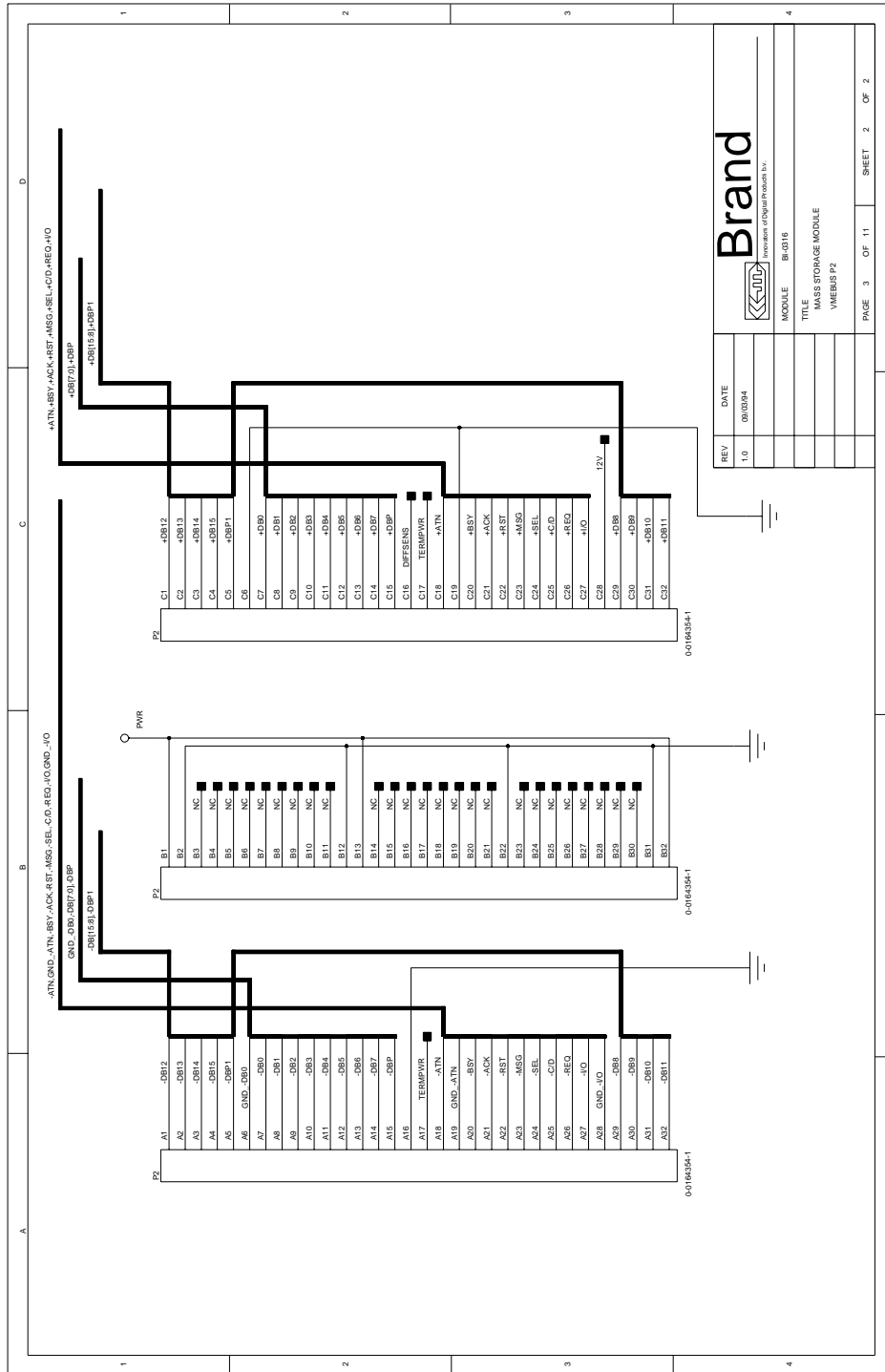

REV	DATE
1.0	08/03/04

MODULE	BR-0316
TITLE	RAMS STORAGE MODULE
	VMEBUS P2

PAGE	3	OF	11
SHEET	2	OF	2



Sheet 4 Power Connectors and LEDs



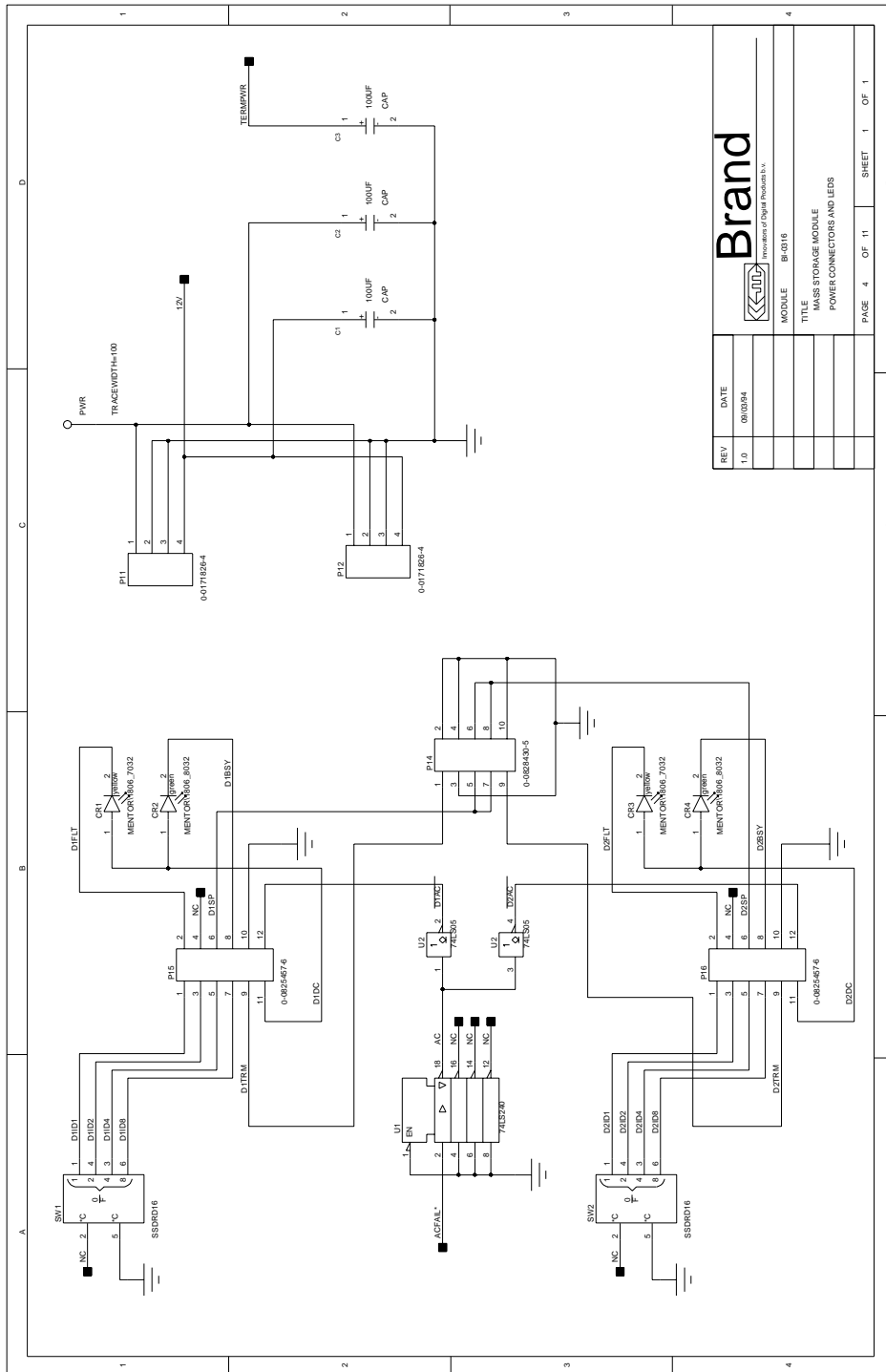



Sheet 6 SCSI-3 Connector P6

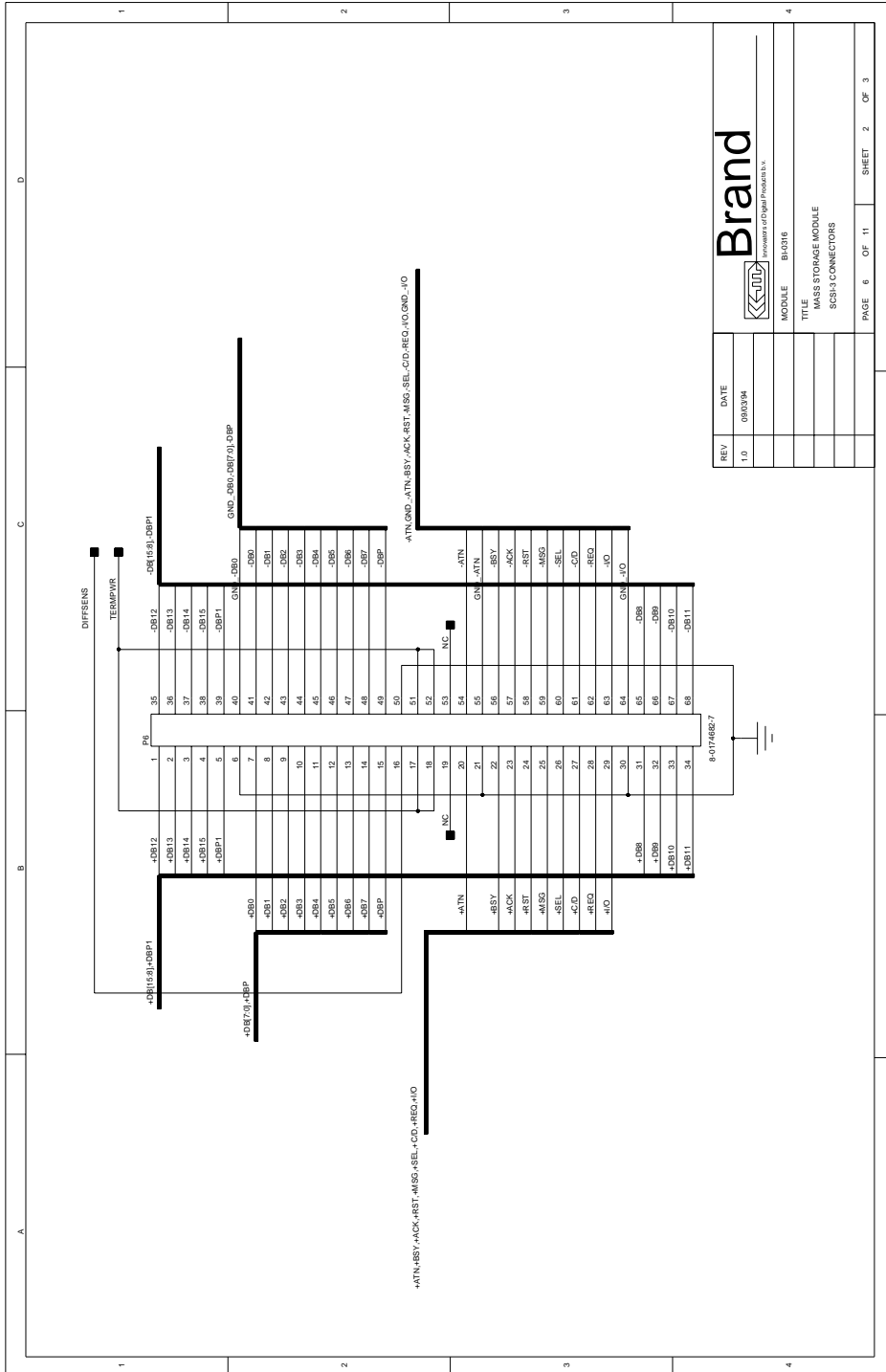

REV	DATE
1.0	09/23/04

 <b>Brand</b> <small>Innovators of Digital Products B.V.</small>
MODULE BH-0316
TITLE MASS STORAGE MODULE SCSI-3 CONNECTORS
PAGE 6 OF 11    SHEET 2 OF 3



Sheet 7 SCSI-3 Connector P3

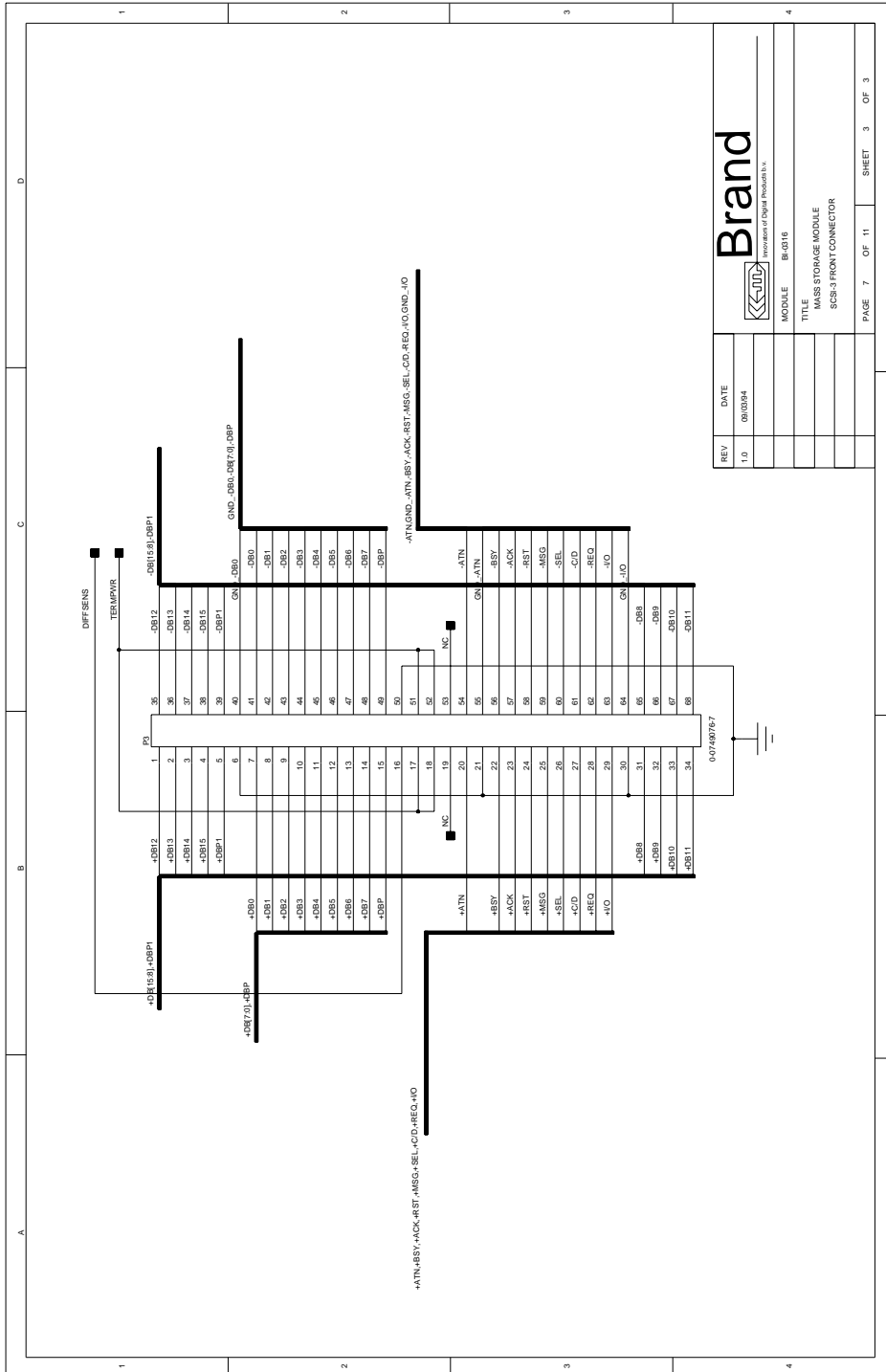

REV	DATE
1.0	09/03/94
MODULE	BI-0316
TITLE	MASS STORAGE MODULE SCSI-3 FRONT CONNECTOR
PAGE	7 OF 11
SHEET	3 OF 3



Sheet 8 SCSI-2 Connector P7

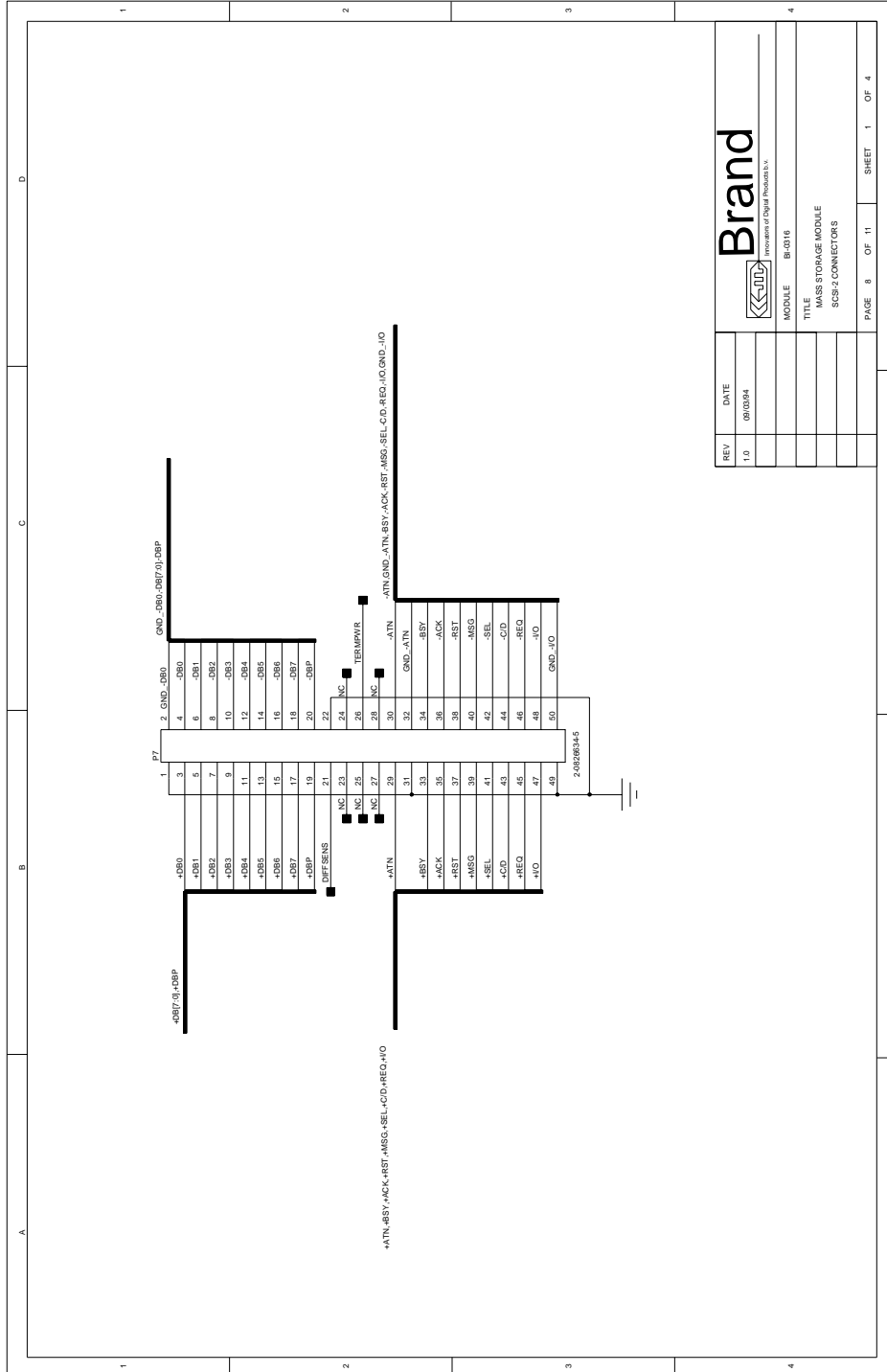

REV	DATE
1.0	09/03/94
 Brand <small>Innovators of Digital Products, Inc.</small>	
MODULE	BI-0316
TITLE	MASS STORAGE MODULE SCSI-2 CONNECTORS
PAGE	8 OF 11
SHEET	1 OF 4



Sheet 9 SCSI-2 Connector P8

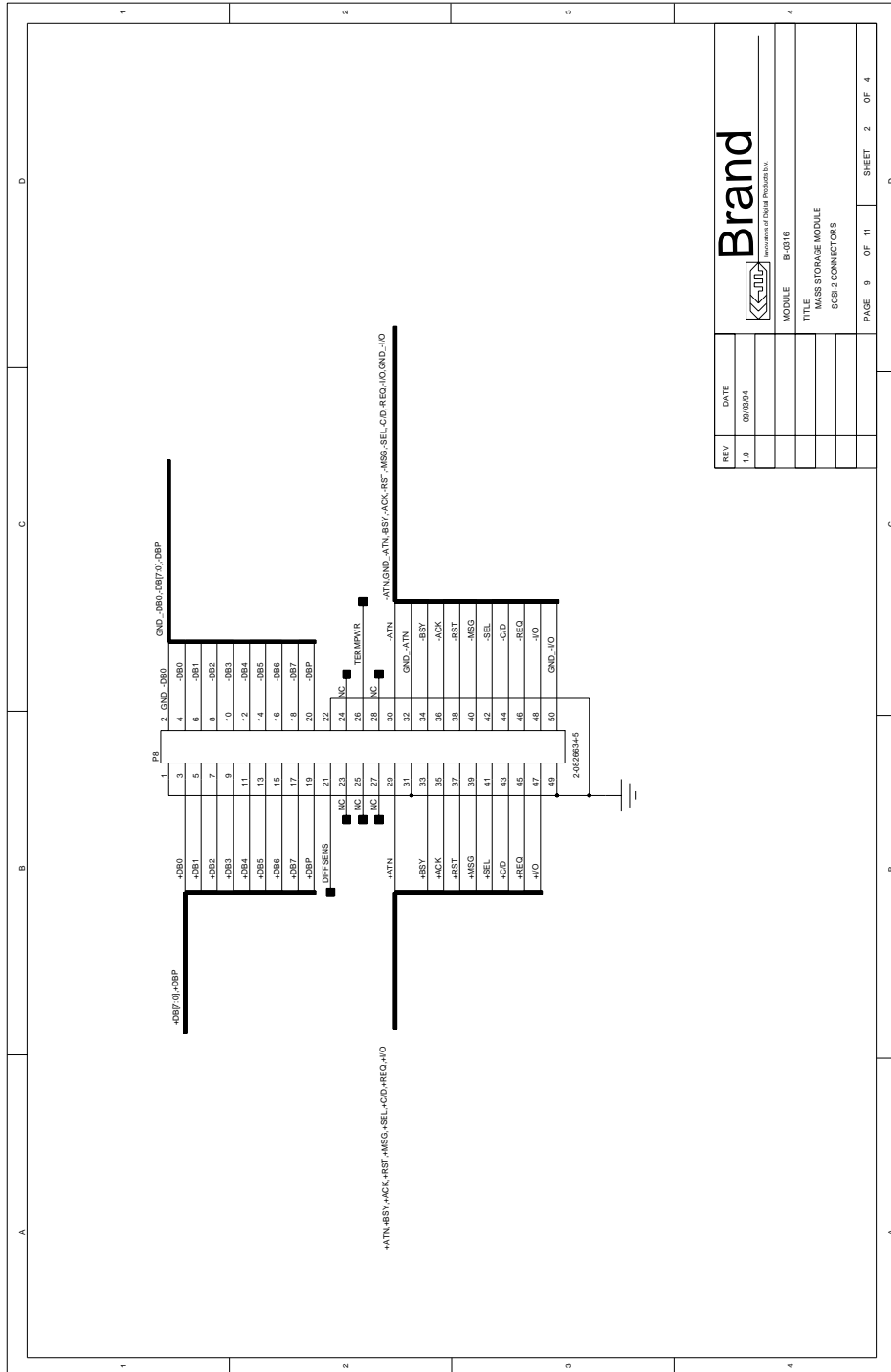

REV	DATE
1.0	09/03/04
 Brand <small>Innovators of Digital Products, Inc.</small>	
MODULE	B-0316
TITLE	MASS STORAGE MODULE SCSI-2 CONNECTORS
PAGE	9 OF 11
SHEET	2 OF 4



Sheet 10 SCSI-2 Connector P9

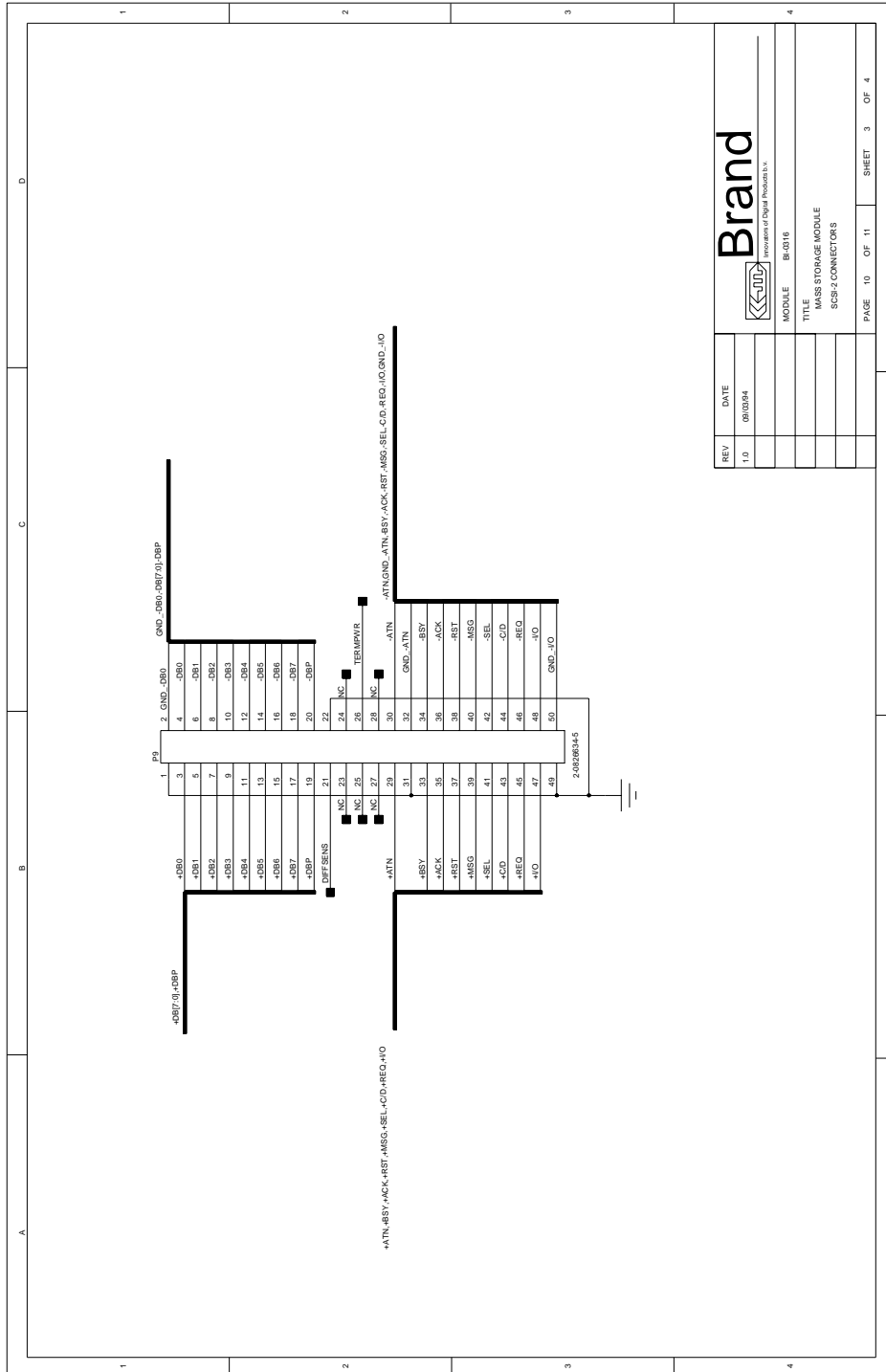

REV	DATE
1.0	09/03/04
 Brand <small>Innovators of Digital Products, Inc.</small>	
MODULE	BI-0316
TITLE	MASS STORAGE MODULE SCSI-2 CONNECTORS
PAGE	10 OF 11
SHEET	3 OF 4



Sheet 11 SCSI-2 Connector P10

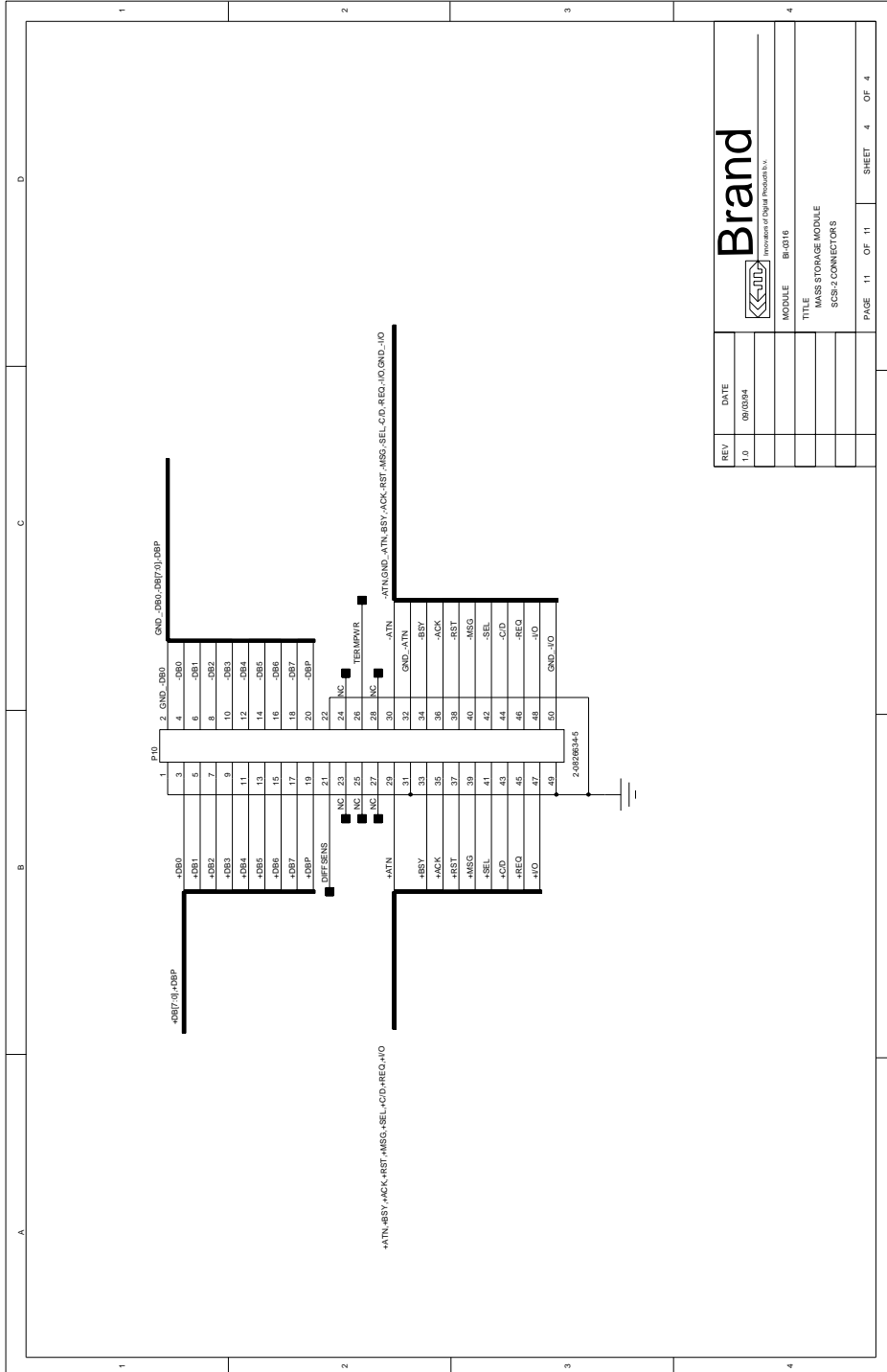

REV	DATE
1.0	09/03/94
 Brand <small>Innovators of Digital Products™</small>	
MODULE	BI-0316
TITLE	MASS STORAGE MODULE
	SCSI-2 CONNECTORS
PAGE	11 OF 11
SHEET	4 OF 4



# Component Layout

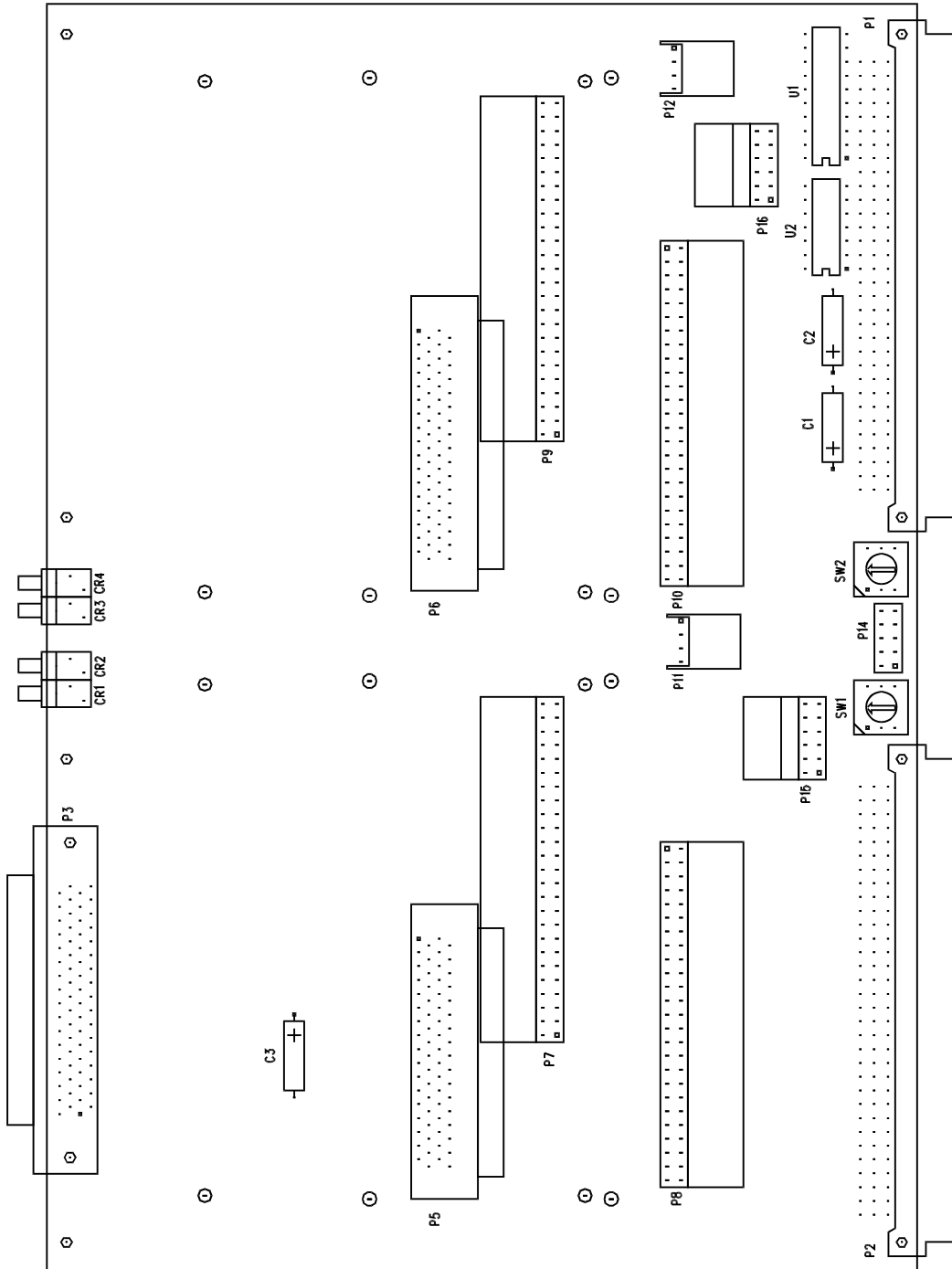

Figure C-1 Component Layout PCB Version 1.0





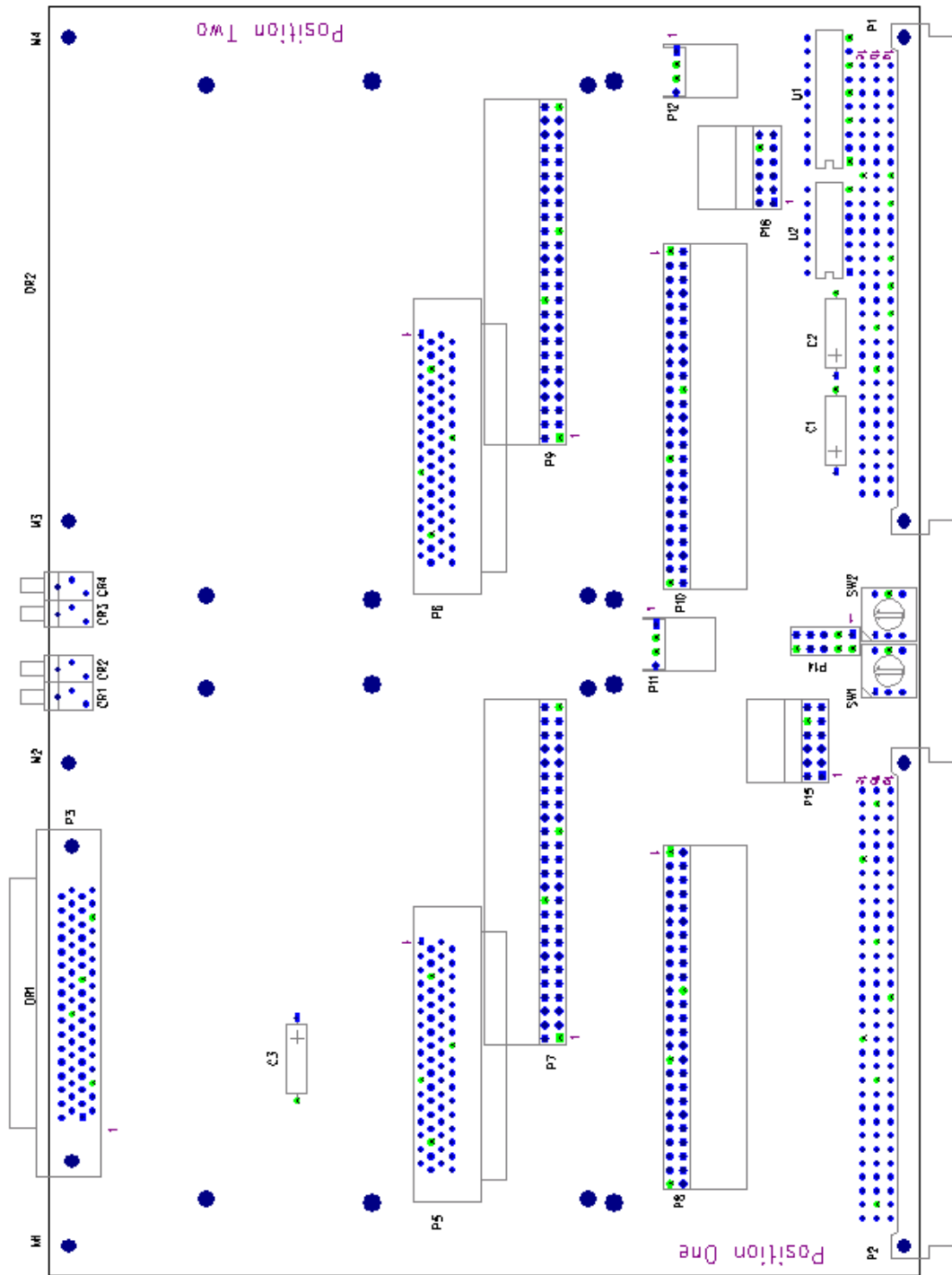

Figure C-2 Component Layout PCB Version 1.1



# List of Components

Table D-1 List of Components

Unit Number	Component	Description
C1-C3	P222203036101	Capacitor 100 $\mu$ F 25 V axial
CR1, CR3	1806.7032	PCB Board Mounting LED, Yellow
CR2, CR4	1806.8032	PCB Board Mounting LED, Green
P1-P2	0-0164354-1	IEC 603-2 Type C Male Connector BTB-(Solder)Version Quality Level 1. No. of Positions: 96
P3	0-0749076-7	AMPLIMITE Subminiature Connector, Receptacle header, Right-Angle mount, No. of positions: 68, Without Rails and Latch Blocks, Series III, Without Boardlocks, With 2.84 Solder Tails
P5-P6	8-0174682-7	AMPLIMITE Subminiature Connector, Receptacle header, Right-Angle mount, No. of positions: 68, With self retaining solder Posts
P7-P10	2-0826634-5	MODU II Pin Header, 2x25 Positions, Right-Angle mount
P11-P12	0-0171826-4	Connector EI-series, 4 Positions, Right-Angle mount
P14	0-0826632-5	MODU II Pin Header, 2x5 Positions
P15-P16	0-0825457-6	MODU II Pin Header, 2x6 Positions, Right-Angle mount
SW1-SW2	DRD16	Rotary DIP Switch, 16 Positions, Through Hole PCB mount
U1	SN74LS240N	Octal Buffers and Line Drivers with 3-State Outputs
U2	SN74LS05N	Hex Inverters with Open-Collector Outputs





# Connector Assignments

Table E-1 VMEbus P1 Assignments

Pin Number	(a) Signal Mnemonic	(b) Signal Mnemonic	(c) Signal Mnemonic
1	(D00)	(BBSY*)	(D08)
2	(D01)	(BCLR*)	(D09)
3	(D02)	ACFAIL*	(D10)
4	(D03)	BG0IN*	(D11)
5	(D04)	BG0OUT*	(D12)
6	(D05)	BG1IN*	(D13)
7	(D06)	BG1OUT*	(D14)
8	(D07)	BG2IN*	(D15)
9	GND	BG2OUT*	GND
10	(SYSCLK)	BG3IN*	(SYSFAIL*)
11	GND	BG3OUT*	(BERR*)
12	(DS1*)	(BR0*)	(SYSRESET*)
13	(DS0*)	(BR1*)	(LWORD*)
14	(WRITE*)	(BR2*)	(AM5)
15	GND	(BR3*)	(A23)
16	(DTACK*)	(AM0)	(A22)
17	GND	(AM1)	(A21)
18	(AS*)	(AM2)	(A20)
19	GND	(AM3)	(A19)
20	(IACK*)	GND	(A18)
21	IACKIN*	(SBUS_DATA)	(A17)
22	IACKOUT*	(SBUS_STRB)	(A16)
23	(AM4)	GND	(A15)
24	(A07)	(IRQ7*)	(A14)
25	(A06)	(IRQ6*)	(A13)
26	(A05)	(IRQ5*)	(A12)
27	(A04)	(IRQ4*)	(A11)
28	(A03)	(IRQ3*)	(A10)
29	(A02)	(IRQ2*)	(A09)
30	(A01)	(IRQ1*)	(A08)
31	(-12V)	(+5V STDBY)	+12V
32	+5V	+5V	+5V

Note: Signal mnemonics shown in parenthesis ( ) are not used by the BI-0316.



Table E-2 VMEbus P2 Assignments (Single-Ended)

Pin Number	(a) Signal Mnemonic	(b) Signal Mnemonic	(c) Signal Mnemonic
1	-DB(12)	+5V	GND
2	-DB(13)	GND	GND
3	-DB(14)	(RETRY)	GND
4	-DB(15)	(A24)	GND
5	-DB(P1)	(A25)	GND
6	-DB(0)	(A26)	GND
7	-DB(1)	(A27)	GND
8	-DB(2)	(A28)	GND
9	-DB(3)	(A29)	GND
10	-DB(4)	(A30)	GND
11	-DB(5)	(A31)	GND
12	-DB(6)	GND	GND
13	-DB(7)	+5V	GND
14	-DB(P)	(D16)	GND
15	GND	(D17)	GND
16	GND	(D18)	GND
17	TERMPWR	(D19)	TERMPWR
18	GND	(D20)	GND
19	-ATN	(D21)	GND
20	GND	(D22)	GND
21	-BSY	(D23)	GND
22	-ACK	GND	GND
23	-RST	(D24)	GND
24	-MSG	(D25)	GND
25	-SEL	(D26)	GND
26	-C/D	(D27)	GND
27	-REQ	(D28)	GND
28	-I/O	(D29)	12V
29	-DB(8)	(D30)	GND
30	-DB(9)	(D31)	GND
31	-DB(10)	GND	GND
32	-DB(11)	+5V	GND

Note: Signal mnemonics shown in parenthesis () are not used by the BI-0316.

Table E-3 VMEbus P2 Assignments (Differential)

Pin Number	(a) Signal Mnemonic	(b) Signal Mnemonic	(c) Signal Mnemonic
1	-DB(12)	+5V	+DB(12)
2	-DB(13)	GND	+DB(13)
3	-DB(14)	(RETRY)	+DB(14)
4	-DB(15)	(A24)	+DB(15)
5	-DB(P1)	(A25)	+DB(P1)
6	GND	(A26)	GND
7	-DB(0)	(A27)	+DB(0)
8	-DB(1)	(A28)	+DB(1)
9	-DB(2)	(A29)	+DB(2)
10	-DB(3)	(A30)	+DB(3)
11	-DB(4)	(A31)	+DB(4)
12	-DB(5)	GND	+DB(5)
13	-DB(6)	+5V	+DB(6)
14	-DB(7)	(D16)	+DB(7)
15	-DB(P)	(D17)	+DB(P)
16	GND	(D18)	DIFFSENS
17	TERMPWR	(D19)	TERMPWR
18	-ATN	(D20)	+ATN
19	GND	(D21)	GND
20	-BSY	(D22)	+BSY
21	-ACK	(D23)	+ACK
22	-RST	GND	+RST
23	-MSG	(D24)	+MSG
24	-SEL	(D25)	+SEL
25	-C/D	(D26)	+C/D
26	-REQ	(D27)	+REQ
27	-I/O	(D28)	+I/O
28	GND	(D29)	12V
29	-DB(8)	(D30)	+DB(8)
30	-DB(9)	(D31)	+DB(9)
31	-DB(10)	GND	+DB(10)
32	-DB(11)	+5V	+DB(11)

Note: Signal mnemonics shown in parenthesis ( ) are not used by the BI-0316.



Table E-4 P3, P5-P6 SCSI-3 Connectors (Single-Ended)

Signal Mnemonic	Pin Number	Pin Number	Signal Mnemonic
GND	1	35	-DB(12)
GND	2	36	-DB(13)
GND	3	37	-DB(14)
GND	4	38	-DB(15)
GND	5	39	-DB(P1)
GND	6	40	-DB(0)
GND	7	41	-DB(1)
GND	8	42	-DB(2)
GND	9	43	-DB(3)
GND	10	44	-DB(4)
GND	11	45	-DB(5)
GND	12	46	-DB(6)
GND	13	47	-DB(7)
GND	14	48	-DB(P)
GND	15	49	GND
GND	16	50	GND
TERMPWR	17	51	TERMPWR
TERMPWR	18	52	TERMPWR
RESERVED	19	53	RESERVED
GND	20	54	GND
GND	21	55	-ATN
GND	22	56	GND
GND	23	57	-BSY
GND	24	58	-ACK
GND	25	59	-RST
GND	26	60	-MSG
GND	27	61	-SEL
GND	28	62	-C/D
GND	29	63	-REQ
GND	30	64	-I/O
GND	31	65	-DB(8)
GND	32	66	-DB(9)
GND	33	67	-DB(10)
GND	34	68	-DB(11)

Table E-5 P3, P5-P6 SCSI-3 Connectors (Differential)

Signal Mnemonic	Pin Number	Pin Number	Signal Mnemonic
+DB(12)	1	35	-DB(12)
+DB(13)	2	36	-DB(13)
+DB(14)	3	37	-DB(14)
+DB(15)	4	38	-DB(15)
+DB(P1)	5	39	-DB(P1)
GND	6	40	GND
+DB(0)	7	41	-DB(0)
+DB(1)	8	42	-DB(1)
+DB(2)	9	43	-DB(2)
+DB(3)	10	44	-DB(3)
+DB(4)	11	45	-DB(4)
+DB(5)	12	46	-DB(5)
+DB(6)	13	47	-DB(6)
+DB(7)	14	48	-DB(7)
+DB(P)	15	49	-DB(P)
DIFFSENS	16	50	GND
TERMPWR	17	51	TERMPWR
TERMPWR	18	52	TERMPWR
RESERVED	19	53	RESERVED
+ATN	20	54	-ATN
GND	21	55	GND
+BSY	22	56	-BSY
+ACK	23	57	-ACK
+RST	24	58	-RST
+MSG	25	59	-MSG
+SEL	26	60	-SEL
+C/D	27	61	-C/D
+REQ	28	62	-REQ
+I/O	29	63	-I/O
GND	30	64	GND
+DB(8)	31	65	-DB(8)
+DB(9)	32	66	-DB(9)
+DB(10)	33	67	-DB(10)
+DB(11)	34	68	-DB(11)





Table E-6 P7-P10 SCSI-2 Connectors (Single-Ended)

Signal Mnemonic	Pin Number	Pin Number	Signal Mnemonic
GND	1	2	-DB(0)
GND	3	4	-DB(1)
GND	5	6	-DB(2)
GND	7	8	-DB(3)
GND	9	10	-DB(4)
GND	11	12	-DB(5)
GND	13	14	-DB(6)
GND	15	16	-DB(7)
GND	17	18	-DB(P)
GND	19	20	GND
GND	21	22	GND
RESERVED	23	24	RESERVED
OPEN	25	26	TERMPWR
RESERVED	27	28	RESERVED
GND	29	30	GND
GND	31	32	-ATN
GND	33	34	GND
GND	35	36	-BSY
GND	37	38	-ACK
GND	39	40	-RST
GND	41	42	-MSG
GND	43	44	-SEL
GND	45	46	-C/D
GND	47	48	-REQ
GND	49	50	-I/O

Table E-7 P7-P10 SCSI-2 Connectors (Differential)

Signal Mnemonic	Pin Number	Pin Number	Signal Mnemonic
GND	1	2	GND
+DB(0)	3	4	-DB(0)
+DB(1)	5	6	-DB(1)
+DB(2)	7	8	-DB(2)
+DB(3)	9	10	-DB(3)
+DB(4)	11	12	-DB(4)
+DB(5)	13	14	-DB(5)
+DB(6)	15	16	-DB(6)
+DB(7)	17	18	-DB(7)
+DB(P)	19	20	-DB(P)
DIFFSENS	21	22	GND
RESERVED	23	24	RESERVED
TERMPWR	25	26	TERMPWR
RESERVED	27	28	RESERVED
+ATN	29	30	-ATN
GND	31	32	GND
+BSY	33	34	-BSY
+ACK	35	36	-ACK
+RST	37	38	-RST
+MSG	39	40	-MSG
+SEL	41	42	-SEL
+C/D	43	44	-C/D
+REQ	45	46	-REQ
+I/O	47	48	-I/O
GND	49	50	GND



Table E-8 P11-P12 Power Connectors

Signal Mnemonic	Pin Number
+5V	1
GND	2
GND	3
+12V	4

Table E-9 P14 Drive Options Jumper Block

Signal Mnemonic	Pin Number	Pin Number	Signal Mnemonic
D1TERM	1	2	GND
GND	3	4	GND
D1SYNC	5	6	D2SYNC
D1SYNC	7	8	D2SYNC
D2TERM	9	10	GND

Table E-10 P15-P16 Drive Options Connector

Signal Mnemonic	Pin Number	Pin Number	Signal Mnemonic
SEL0-	1	2	XTFALT-
SEL1-	3	4	VUNIQ-
SEL2-	5	6	SPSYNC-
SEL3-	7	8	XTACTV-
ENTERM-	9	10	GROUND
+5V	11	12	FAULT-

# Appendix F Drive 1 Manual

**Table F-1 Jumper Setting Drive 1**

<b>QM304550PXLW Jumper Function</b>	<b>Factory Default Setting</b>	<b>Brand Innovators Setting</b>	<b>User Setting</b>
SCSI ID	A1 and A2 installed = 6	all removed = 0	see SW1
WAIT-SPIN	removed = spin with power up	removed	
Spin Delay	removed = wait spin disabled	removed	
SE	removed = LVD auto switch	installed	
TE	installed = termination enabled	removed	see P14
TP	installed = termination power	installed	





# Appendix G Drive 2 Manual

**Table G-1 Jumper Setting Drive 2**

Jumper Function	Factory Default Setting	Brand Innovators Setting	User Setting
No Drive Installed			



